

Design Of Hybrid Active Dc Filter For HvdC Converter

^[1] Snehal Shirbhate, ^[2] Prof D.A. Shahakar

^[1] PG student P. R. Pote College of Engineering & Technology, Amravati, Maharashtra, India.

^[2] Assistant Professor Electrical Engineering Department P. R. Pote College of Engineering & Technology, Amravati, Maharashtra, India.

^[1] Snehal.shirbhate89@gmail.com

Abstract: In HVDC (High Voltage Direct Current) system there are two converters one at transmitting end and other at receiving end one operating as rectifier and other as inverter, the converters produce current harmonics that interference into the DC transmission lines and the AC grid. Since the harmonics increase transmission losses, and overheating of the equipment, insulation failure, the combination of passive filter and Active filter have been used to reduce the harmful effects of the harmonic currents. Active power and passive filters (APF and PF) are the traditional ways of compensating the harmonics. However, both of the filters have some problems, namely resonance and tuning problems in passive filters (PF), and capacity, establishment cost of active filter is high so HADF (HYBRIDE ACTIVE DC FILTER) are used to suppress harmonics on DC transmission lines connected with passive filter. Removing the harmonic component of DC transmission line current is carried out by Hybrid Active DC Filter (HADF), by injecting the compensating current into the DC transmission line to suppress the DC transmission line current harmonics significantly.

Keywords: HVDC Transmission Line, Active DC Filter

I. INTRODUCTION

There are various advantages of HVDC over HVAC like long, high power transmission, no limit in transmitting distance, interconnection between two asynchronous systems because of mention advantage HVDC become an economically feasible and competitive alternative to the high voltage alternating current (AC) transmission. The HVDC technology is a high power electronics technology used in electric power systems. It is an efficient and flexible method to transmit large amounts of electric power over long distances by overhead transmission lines or underground/submarine cables. Because of advance semiconductor technology, it is possible to operate converters at very high voltage and current ratings. Modern active power filters are capable to compensate high order harmonics dynamically. Shunt active power filter maintains source current nearly sinusoidal, but some distortion is observed due to the presence of higher order harmonics (greater than 25th). A passive high pass filter can be used to filter out these harmonics (of order more than 25). Hence a combination of APF and passive HPF is one of the most effective way to filter out harmonics present in the power system. These filters are able to reduce the harmonics percentage much lower than selective passive filters and also provide compensation for the loss occurring in the transmission system. Shunt hybrid active filter is the main concern of this research work is formed by the use of a single phase voltage source inverter, and a series connected

passive filter. The series connection between the passive filter and the voltage source inverter is made directly, without using a transformer.

In this paper, the control method mentioned in [1], has been applied to control the HADF. The proposed control strategy is simulated in MATLAB SIMULINK and the results are presented.

II. PRINCIPLE OF HADF

A typical HADF configuration, including components and their interconnections, are represented by the generalized block diagram as shown in Figure 1. That is, the active part is connected to the high voltage bus through a passive part.

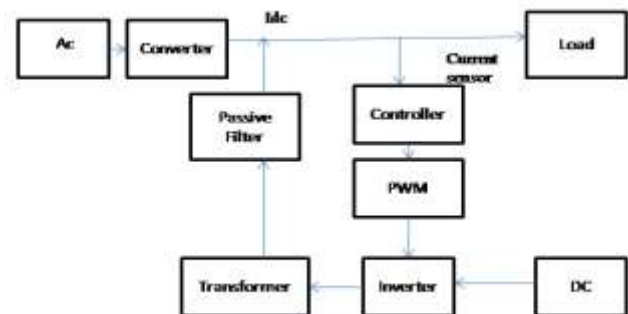

Fig.1 Block diagram of HADF

The harmonic current generated by the HVDC converter, is sensed and supplied to the reference current estimator. The active filter controller generated signal and determining the instantaneous compensating current reference, which is continuously passed to PWM converter. The shunt active filter controller works in closed loop manner, continuously sending the harmonic current and calculating the instantaneous value of the compensating current reference for PWM converter. PWM should have high switching frequency (f_{pwm}) in order to reproduce accurately the compensating current

$$f_{pwm} > 10 * f_{h_{pwm}}$$

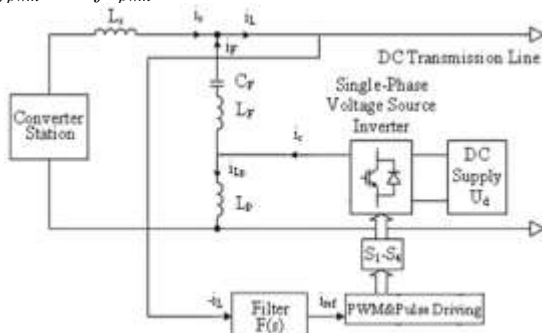

Fig 2. Diagram of the modified HADF configuration[1]

$U_s(s)$: is the harmonic voltage output of HVDC converter

L_s : is the inductance of smoothing reactor,

$I_s(s)$: is the harmonic current generated by HVDC converter,

$Z_f(s)$: is the impedance of single-tuned passive filter,

$I_f(s)$: is the harmonic compensating current of passive filter branch,

$I_c(s)$: is the harmonic compensating current generated by active part of the HADF,

$I_L(s)$: is the DC transmission line harmonic current and

$Z_L(s)$: is the impedance of DC transmission line and remote load

The rectified current and voltage of HVDC converter has a DC component and an AC component or ripple. For example the harmonic current of HVDC converter can be written as:

$$i_s = i_{sdc} + i_{sac}$$

HADF generates the compensating current $I_f(s)$ and injects it to the DC transmission line as follows:

$$i_f = -i_{sac}$$

DC transmission line current i_L can be written as:

$$i_L = i_s + i_f$$

To compensate the current harmonics of a nonlinear load in power systems, the source current should be extracted which is the sum of main sinusoidal component and harmonic components. The harmonic content of source current will be used to calculate the reference current. The derived reference current should be modulated to generate the associated pulses that order the inverter switches to inject

the appropriate current into the system which can compensate the load harmonics $i_L = i_{sdc} + i_{sac} - i_{sac}$

$$i_L = i_{sdc}$$

So we are getting pure DC output Voltage

A. Passive Filter

A number of solutions are there to reduce the undesirable harmonic effects. The common and low cost solution is the installations of passive filter to remove the harmonics. The main function of the passive part is to connect the active part with the high voltage DC line. In a recent project with long HVDC lines, resistive elements in the passive part of the DC filter have been inserted to reduce the resonance in the overall system. However, passive filter implementations to filter out the harmonics have the following disadvantages:

- 1) Possibility of resonances with the source impedance
- 2) Supply impedance dependent system performance
- 3) Fixed compensation characteristic and upgrade difficulty.

B. Active filter

Enhancement in semiconductor technology increases the harmonic effects. In order to overcome the problem occurred with the passive filter, Active power filter developed in the recent year with improvement in semiconductor switches. The dc capacitor and IGBT diode with anti parallel diode are used to indicate the active filter. Active DC filter include an inverter to produce the reference current .firstly the reference current is calculated based on the system current harmonics and extracted to calculate the compensating current. Afterwards, the switching methods such as SPWM, HCC and etc., are used to generate and inject the calculated reference current.

Hysteresis current control is a method of controlling a voltage source inverter so that generating appropriate gating signals for the power switches that forces the filter current follow derived reference current. The HCC technique is the easiest and cheapest PWM method to implement and control APF with some characteristics like high accuracy, good dynamic performance and stability [2]. Due to existence of U_d , switching operation of IGBT switches and conversion of dc voltage to ac voltage on the active part of HADF, the waveform of U_{af} will be square hence the switching is produced on the dc transmission line current. In the method mentioned in [3], the current of dc transmission line current is taken from dc line and then is filtered by designed filter $F(s)$ and is multiplied by the gain G then the product is transferred to the PWM program as the PWM modulating signal. The PWM program generates a pair of complementary PWM signals [4]. This paper proposes a new method that its structure and operation thoroughly independent of dc transmission line and its parameters and its current.

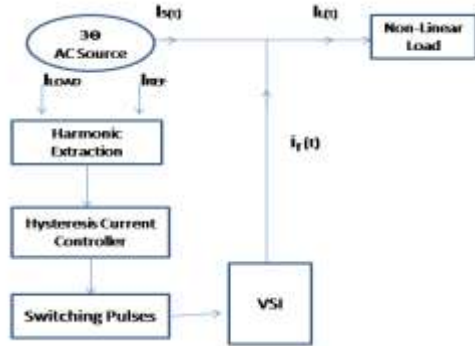

Fig .3.Flow chart for Hysterisis control

C. Master Control unit for Active filter

Active filter controller is a control algorithm implemented in the controller of the shunt active filter determines the compensation characteristics of the shunt active filter. There are many ways to design that algorithm one of them is the fixed band Hysterisis control Algorithm.

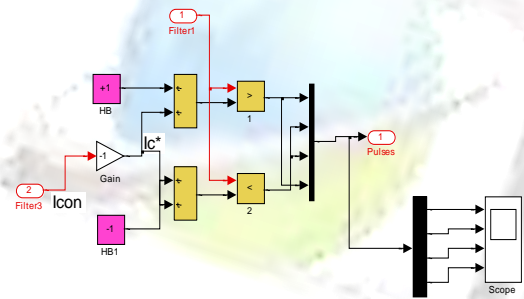

Fig. 4 Master Control unit for Active filter

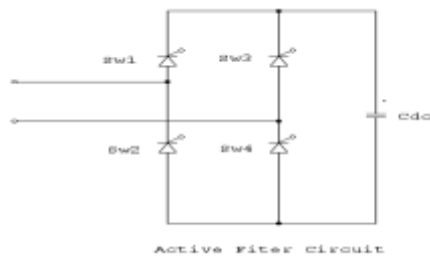

Fig.5 single-phase VSI topology

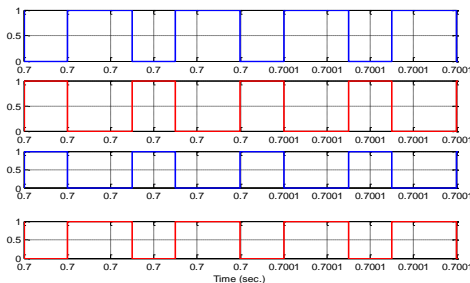

Fig.6 Switching Pulses for Active Filter

The operating principle of the hysteresis band current controller which is shown in Fig. 4 depends on comparing of measured APF output current with its reference by the hysteresis comparator. The hysteresis comparator is implemented by presetting the upper and lower tolerance limits which need to be compared to the actual filter signal. The outputs of the comparator are the power switch gating signals. If the measured filter current is bigger (half of the band value) than the reference one, it is necessary to commute the corresponding power switches to decrease the output current, and it goes to the reference. On the other hand, if the measured current is less (half of the band value) than the reference one, the switches commute to increase output current and it goes to the reference.

III. SIMULATION MODEL

The corresponding simulation model is as shown below, the simulation of HVDC system with HADF for harmonic suppression of dc transmission line current, For implementation of HVDC system in this software, the equivalent circuit shown in Fig. is applied. Here the harmonic compensation has been done using Active filters & passive filter which comprises of single tuned passive filter. tuned to 6th, 12th and 24th part of fundamental frequency respectively. The Sinusoidal pulse width generator components are used for triggering of pulses at the rectifier and inverter ends of the system.

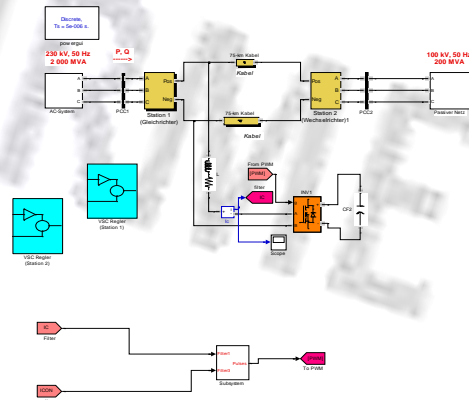

Fig.7 Simulation Model Of Hybrid Active Dc Filter:

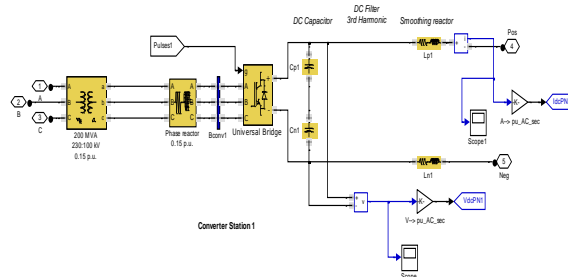

Fig.8 Internal Matlab/simulink Model of AC to DC Conversion System of HVDC

For AC to DC Conversion AC to Dc Switching logic All positive & Negative peak cycle Switch must be ON.

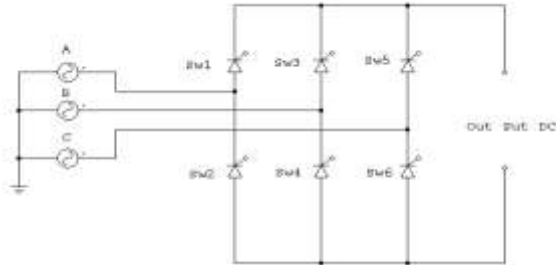

Fig.9 three -phase VSI topology

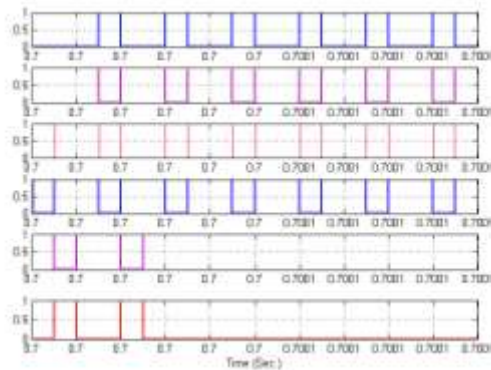

Fig.10 Switching Pulses for Rectification Operation (AC to DC)

IV. RESULT ANALYSIS

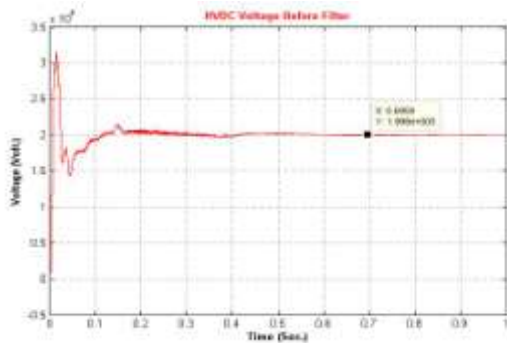

Fig.11 HVDC voltage before filter

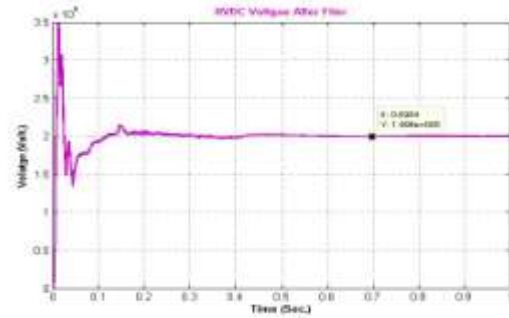

Fig.12 HVDC voltage after filter

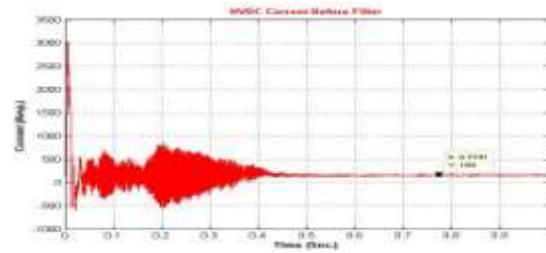

Fig.13 HVDC current before filter

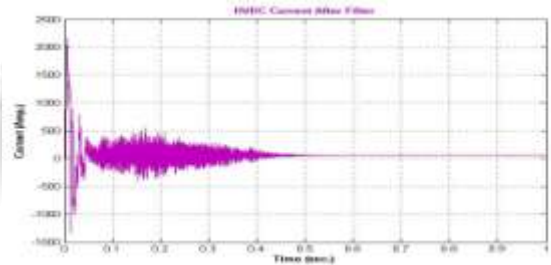

Fig.14 HVDC current before filter

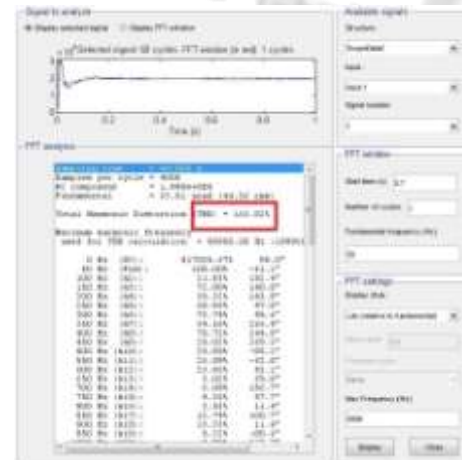

Fig.15 THD Analysis of Voltage Before Filter

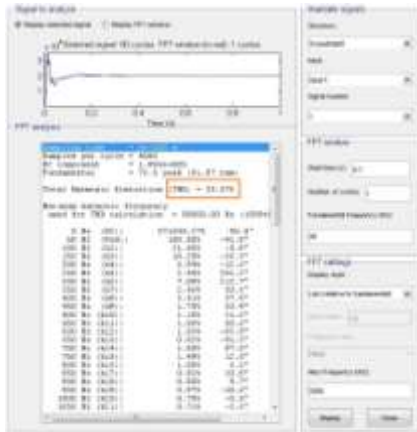

Fig.16 THD Analysis of Voltage After Filter

TABLE I
COMPARISON OF RESULT ANALYSIS OF VOLTAGE

| Sr.No | Before Filter | After Filter |
|--------------|---------------|--------------|
| | Voltage | |
| THD Analysis | 166.82% | 35.57% |
| H2 | 72.98% | 10.29% |
| H12 | 23.96% | 1.09% |
| H24 | 1.05% | 0.73% |
| H36 | 0.56% | 0.31% |
| H48 | 0.08% | 0.03% |

The analysis has been carry forward in Mat Lab and Simulink for DC line generated from a 230KV,3 ϕ ,50Hz AC system having the line impedance of 0.00139 and 1mH.The 6 pulse converter system is used to find out the DC output for 45 degree firing angle. The 150km transmission line has been done for PI network having and 0.00139 line resistance, 0.00159 line inductance and 0.23100MH,line capacitance per km.

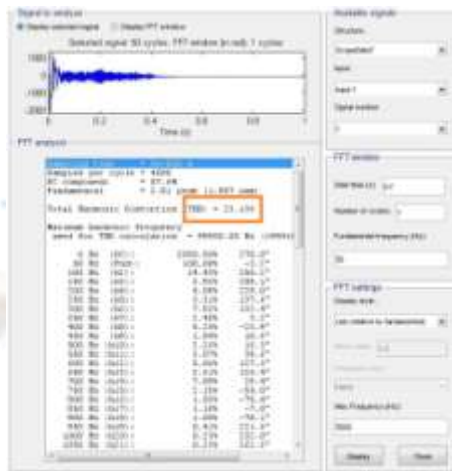

Fig.17 THD analysis of current before filter

TABLE II
COMPARISON OF RESULT ANALYSIS OF CURRENT

| Sr.No | Before Filter | After Filter |
|--------------|---------------|--------------|
| | Current | |
| THD Analysis | 76.80 % | 6.98% |
| H2 | 51.20% | 5.06% |
| H12 | 1.86% | 0.61% |
| H24 | 1.05% | 0.10% |
| H36 | 0.44% | 0.03% |
| H48 | 0.08% | 6.98% |

The value of smoothing reactor is 8.0e-3. The passive filter in series with active part of HADF adopts 918.88 Hz single-tuned filter. Values of the passive filter parameters are: R= 0.01ohm, L = 5.12 mH. The frequency of carrier wave is 135000 Hz. The value of C1 and C2 is 70 μ F.

Because in ideal case the line current has to be negligible as compared to the voltage developed. From Table I and TableII we can see that the harmonic get suppress after the application of HADF.

V. CONCLUSION

In this paper a modified configuration of hybrid active DC filter was proposed in HVDC transmission system for harmonics elimination of DC transmission line current.As per the analysis given we can see that the hybrid active filter is able to reduce the THD of the output waveform appreciably.

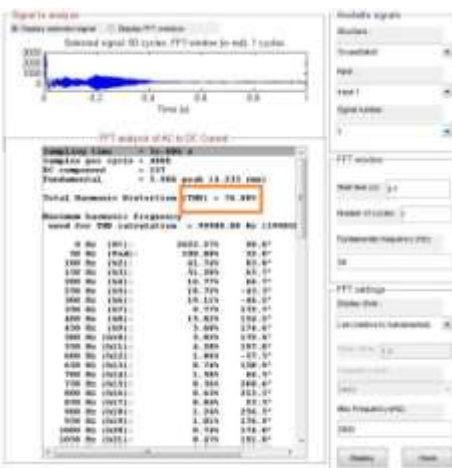

Fig.18 THD analysis of current before filter

VI. REFERENCES

- [1] Hajibeigy M. Farsadi Kh. Behboudi Asl ‘‘A modified structure of hybrid active dc filter in HVDC system’’ Vol 4 10 (1).pp11-16 March 2012.
- [2] Vahedi H, Sheikholeslami .A, Bina M.T, ‘‘Reverse Direction of Hysteresis Bandwidth Calculation to Fix the Switching Frequency Employed in Active Power Filter’’, World Applied Sciences Journal vol.15 (7) pp.1007- 1011, 2011.
- [3] Tabatabaei .N.M, Taheri.N, Boushehri N.S ,‘‘Damping Function of Back to Back HVDC Based Voltage Source Converter’’, International Journal on Technical and Physical Problems of Engineering (IJTPE), Issue 4, Vol. 2, No. 3, pp. 82-87, September 2010.
- [4] Ahmad K.H, Hamad M.S., Finney S.J., Williams B.W., ‘‘DC-Side Shunt Active Power Filter for Line Commutated Rectifiers to Mitigate the Output Voltage Harmonics’’, IEEE Energy Conversion Congress and Exposition (ECCE), pp. 151-157, Atlanta, USA, Sep.2010.
- [5] Hao.P, Zanzi.W, Jianye C, ‘‘Study on the Control of Shunt Active DC Filter for HVDC Systems’’, IEEE Transactions on Power Delivery, Vol.23,No.1,pp.396-401,Jan.2008.
- [6] Zhang.W, Isaksson A.J., Ekstrom A., ‘‘Analysis on the Control Principle of the Active DC Filter in the Lindome Converter Station of the Konti-Skan HVDC link’’, IEEE Trans. on Power Systems, Vol. 13, No. 2, pp.374-381, May 1998.
- [7] Xiao L.J., Zhang L., ‘‘Harmonic Cancellation for HVDC Systems Using a Notch-Filter Controlled Active DC Filter’’, Proc. Inst. Elect. Eng., Gen., Transm. Distrib., Vol. 147, No. 3, pp. 176-181, May 2000.
- [8] Gelan.Z., Zhen.R., ‘‘A Study of Hybrid DC Filter for HVDC System’’, Elect. Power Autom. Equipment, Vol.21, No. 8, pp. 5-7, Aug. 2001.
- [9] Ma. Hajibeigy, M. Farsadi, D. Nazarpour, H.Golahmadi, Me. Hajibeigy, ‘‘Harmonic Suppression in HVDC System Using a Modified Control Method for Hybrid Active DC Filter’’, European Transactions on Electrical Power, DOI: 10.1002/etep562. Article first published online in Wiley Online Library(wileyonlinelibrary.com) on 19 Jan. 2011.
- [10] Dongyuan.Z, Xinjie.Y, Jianye.C, Zanzi.W, Bin.L, ‘‘Novel Control Schemes for the Hybrid Filter Applied in HVDC According to the Different Harmonic Measurement schemes’’, IEEE 34th Annual Power Electronics Specialist Conference (PESC), Vol. 2, pp.537-541, June 2003.conference)
- [11] A practical approach to harmonic compensation in power system-series connection of passive and active filter by H Fujita & H Akagi.(IEEE Transaction on Industry application, vol.27 no 6, November/December 1991)

BOOKS:

1. HVDC Power Transmission system by K R Padiyar.
2. EHV-AC, HVDC Transmission Distribution by S.Rao
3. Power Quality Enhancement using Custom Power Devices by A Ghosh & G Ledwich.
4. Power Electronics by Mohan ,Undeland & Robbins.