

A Smart Farmland Using Raspberry Pi For Crop Prevention And Animal Intrusion Detection System

^[1]Y.Damodharan, ^[2]E.Kavipriya, ^[3]S.Santhiya, ^[4]CS.Santhosh, ^[5]M.Surekha
^{[1][2][3][4]}UG Student, ^[5]Assistance professor Knowledge Institute of Technology, Salem-637504.

Abstract: This project is used to protect the farmland from animals by using Raspberry pi. Wild animals are special challenge for the farmers throughout the world. Animals like wild boars, elephants, monkeys etc...cause serious damage to crops. This project utilizes the RFID (Radio Frequency Identification Device) module and GSM (Global System Mobile) modem for this purpose. Forest officer and farmers will get these SMS containing area in which that animals observe. The techniques that already being used is ineffective, in this article we are presenting a practical procedure to ward them off, by creating a system which studies the behavior of the animal, detects the animal and creates the different sound that irritates the animal and also alerts the authorized person by sending a message. The animal can be detected by the RFID injector (for animals), the LF tag which inject under the animal skin. After the detection the intimation is sent. This project is mainly contributed to repellent the animals to the forest by using three stages are intimation, irritation noise and smoke by fog machine.

Keywords: Raspberry pi, GSM, RFID Injector, Fog Machine.

I. INTRODUCTION

In recent years wild animals are special challenge for the farmers throughout the world, Animals like wild boars, elephant, tiger and monkeys etc..... cause serious damage to crops by animals running over the field and trampling over the crops. It causes the financial problem to the farmers. To overcome this problem we give a solution in this paper. This project is used to protect the farmland by using raspberry pi. This project utilizes the RFID (Radio Frequency Identification) module and GSM (Global System Mobile) modem for this purpose. Forest officer and farmers will get these SMS containing area in which that animals observe. Radio frequency identification (RFID) is used to describe a system that transmits the identity (in the form of a unique serial number) of an object wireless, using radio waves. The RFID injector tag is designed for injection under an animal skin. It is inject in the animal skin, if the animals enter into the farm land the RFID reader detect the animal and send the message to the forest officer and farmers using GSM. And also the animals repellent to the forest by using irritation noise by speaker and creating smoke by fogging machine.

II. LITERATURE SURVEY

[1] Prevention of Wild Animals Entering Into the Agriculture Fields

Bindu D and Dilip kumar M D et al describes their in this paper, the conservation of crop field has been a main content and a complex issue. The animals from the protected area [PAs] are continuously attacking the crop field over the years and the protection of this crop field has become a main concern. The techniques that already being used is ineffective, in this article we are presenting a practical procedure to ward them off, by creating a system which studies the behavior of the animal, detects the animal and creates the different sound that irritates the animal and also alerts the authorized person by sending a message. We also provide a multi-class classification by presenting zero false alarm rate and accurate species identification.

[2] Solar Fencing Unit and Alarm for Animal Entry Prevention

Krishnamurthy B, Divya M et al describes the Agriculture meets food requirements of the people and produces several raw materials for industries. But because of animal interference in agricultural lands, there will be huge loss of crops. Crops are

vulnerable to wild animals. Therefore, it is very important to monitor the nearby presence of animals. Then the actuation of various devices should follow to repel the hazardous animals. We propose a method to protect farms from wild animals. Operational amplifier circuits are utilized mainly for the detection of animal intrusion from the outside of farms. The proposed monitoring scheme is to provide an early warning about possible intrusion and damage by wild animals. The Solar Electric Fence system is a modern day alternative to conventional methods of fencing to protect your crops & property. Electric Fence is an effective way to reducing losses caused by animals.

[3] Wildlife Animal Tracking Using RFID and GSM Technology

Kshama s.Bhise describes the project is used to track the location of Animal in the wildlife reserves or national parks. This project utilizes a RFID (Radio Frequency Identification Device) module and a GSM (Global System Mobile) modem for this purpose. Forest officer or Government authority person will get these SMS containing area in which that animals observe. Radio frequency identification (RFID) is used to describe a system that transmits the identity (in the form of a unique serial number) of an object or person wireless, using radio waves. It's grouped under the broad category of automatic identification technologies. This paper is used to track the location of Animal in the wildlife reserves or national parks. This paper utilizes a RFID module and zig bee for this purpose. Forest officer or Government authority person will get these SMS containing area in which that animals observe.

[4] Design and Implementation of an Intelligent Security System for Farm Protection from Wild Animals

Prof. Abhinav V. Deshpande describes the proposed method to protect farms from wild animals via ubiquitous wired network devices, which is applied to farm along with traditional methods to improve the protection performance. Operational amplifier circuits are utilized mainly for the detection of animal intrusion from the outside of farms. The proposed monitoring scheme is to provide an early warning about possible intrusion and damage by wild animals.

[5] IOT Based Wireless Sensor Network for Prevention of Crops from Wild Animals

S. R. Chourey , P. A. Amale et al describes the paper provides review for complete technical solution using wireless sensor network (WSN) and Internet of Things (IOT) to the farmers to prevent their crops from wild animals. It includes all the types of sensors, controller, actuator required for WSN and raspberry pi as a heart of the system.

3 Existing Method

In Existing method electric fences used to protect the crops from the wild animals. Due to high electricity animals are hurt widely and it is not only affects wild animals it also dangerous to the pet animals and even human beings. The electric fences is used for preventing the crops but in existing method camera was used for detecting the animals which is economically high cost. The indication is available in the system but it send the message only to the forest officer not to the leaving people in the farmland.

4 Proposed Method

In the proposed method, the entire process done by using Raspberry pi and it consist of three stages for animal repellent. We are using Radio Frequency Identification for detecting the animal enter into the farmland so it has multi usage like detection, counting animals in the forest and also track the animals using GPS and it is cost economical. In this method the alert message not only sent to the forest officer it also send the message to the living people in the farmland by using GSM. The RFID tag is injected in the animal skin by the RFID injector which is the recent technology. If the animal reaches the particular place the

RFID Reader reads the And the intimation of detected animals send through the SMS by GSM modem then repellent the animal to the forest by preventing intrusion in farmland using irritation noise and cracker sound made by the speaker.

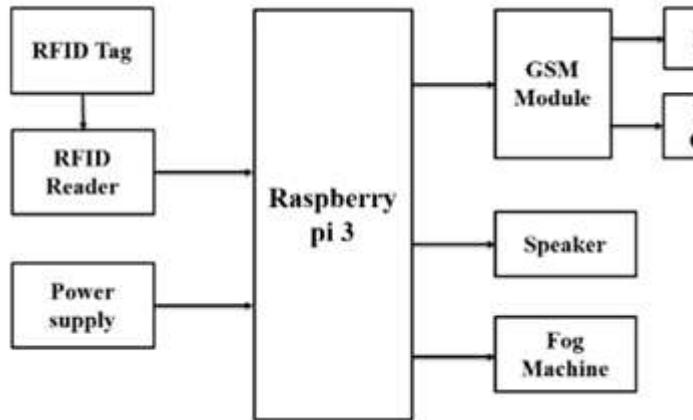

Fig: Functional Block Diagram

Raspberry pi

Raspberry pi is a small credit-card sized computer capable of performing various functionalities such as in surveillance systems, military applications, etc. The various functionalities of the components are given below the various components of Raspberry- Pi are

- SD Card Slot is used to install OS/booting/long term storage .The total memory of the SD card is about 16GB.
- Micro USB Power Port provides 700mA at 5A. RCA Video Out is connected to display if HDMI output is not used. It is mainly used to carry audio and video signals. They are otherwise called as A/V jacks.
- Audio Out Digital audio is obtained if HDMI is used to obtain stereo audio. Here analogue RCA connection is used.
- Ethernet Port is used to connect to the Internet. It also plays a role in updating, getting new software easier. • HDMI OUT (High Definition Multimedia Interface) is used with HDTVs and monitors with HDMI input. Also HDMI-HDMI is used here.
- BROADCOM BCM2835:
It is otherwise defined as System on chip .It is a 700 MHz Processor. It has a Video core IV GPU. GPIO allows us to control and interact with real world.

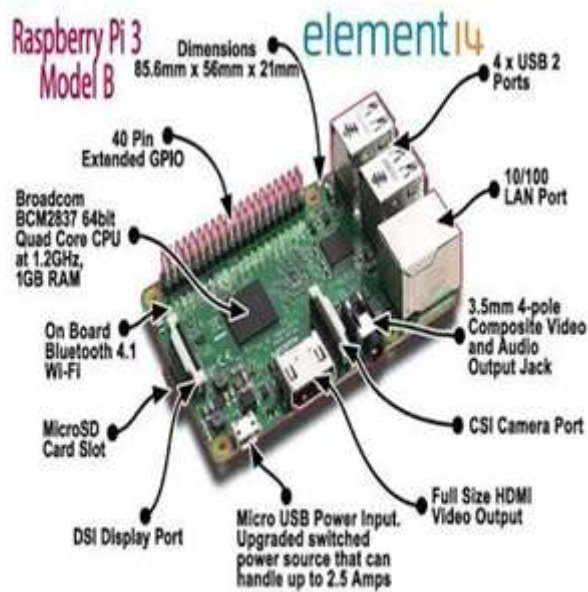

Fig: Raspberry Pi

Radio Frequency Identification

Many types of RFID exist, but at the highest level, we can divide RFID devices into two classes: active and passive. Active tags require a power source—they're either connected to a powered infrastructure or use energy stored in an integrated battery. In the latter case, a tag's lifetime is limited by the stored energy, balanced against the number of read operations the device must undergo. One example of an active tag is the transponder attached to an aircraft that identifies its national origin. Passive RFID is of interest because the tags don't require batteries or maintenance. The tags also have an indefinite operational life and are small enough to fit into a practical adhesive label. A passive tag consists of three parts: an antenna, a semi-conductor chip attached to the antenna, and some form of encapsulation.



Fig: RFID Pet Microchip



Fig: RFID INJECTOR

The Specification of RFID injector are Life time is 30 years above, Frequency of RFID injector is 134.2 kHz, Memory is 64 bits, Size of injector 12mm(length) & 2.12mm(diameter) and Material made by Bio glass & paralyne coated.

GSM modem

A GSM modem is a specialized type of modem which accepts a SIM card, and operates over a subscription to a mobile operator, just like a mobile phone. From the mobile operator perspective, a GSM modem looks just like a mobile phone. When a GSM modem is connected to a computer, this allows the computer to use the GSM modem to communicate over the mobile network. While these GSM modems are most frequently used to provide mobile internet connectivity, many of them can also be used for sending and receiving SMS and MMS messages. GSM modems can be a quick and efficient way to get started with SMS, because a special subscription to an SMS service provider is not required. In most parts of the world, GSM modems are a cost effective solution for receiving SMS messages, because the sender is paying for the message delivery. A GSM modem could also be a standard GSM mobile phone with the appropriate cable and software driver to connect to a serial port or USB port on your computer.



Fig: GSM

FEATURES OF GSM KIT:

- GSM is a highly flexible plug and play quad band
- GSM modem integration to RS232
- Supports features like voice, data/fax, SMS, GPRS and integrated TCP/IP stack
- Control via AT commands (GSM07,07,07,05 and enhanced AT commands)
- Use AC-DC power adapter with ratings are DC voltage 12V/1A
- Current consumption is 250mA.

Fog machine

A fog machine, fog generator or smoke machine is a device that emits a dense vapor that appears similar to fog or smoke. This artificial fog is most commonly used in professional entertainment application. Fog is created by vaporizing proprietary water and glycol base or glycerin based fluids or through the atomization of mineral oil. The specification of fog machine is high efficiency heater block burns through fog with fewer residues. Warm up time is 5 minutes it has fluid level indicator.

III. CONCLUSION

The problem of damaging crops by wild animals has become a major social problem in the current time. It requires urgent attention and an effective solution. Thus this project carries a great social relevance as it aims to address this problem. The proposed system based on Raspberry pi is found to be more compact, user friendly and less complex, which can readily be used in order to perform. Several tedious and repetitive tasks. In this project the process is fully automated and it does not cause any hurt to animal during repellent. Future scope in this project is to detect the location of the animals by using RFID injector and GPS.

References

- [1] Bindu D et al, International Journal of Engineering, Basic sciences, Management & Social studies, Volume 1, Issue 1, May 2017.
- [2] Krishnamurthy b et al, International Journal of Latest Engineering Research and Applications (IJLERA) ISSN: 2455-7137, Volume – 02, Issue – 05, May – 2017, PP –128-135.
- [3] Kshama s.Bhise, International Journal of Scientific & Engineering Research, Volume 7, Issue 2, February-2016 ISSN 2229-5518.
- [4] V. Deshpande, International Journal of Science and Research (IJSR) ISSN (Online): 2319-7064 Index Copernicus Value (2013):6.14 | Impact Factor (2014): 5.611.
- [5] S. R. Chourey, P. A. Amale et al, IETE Zonal Seminar “Recent Trends in Engineering & Technology”-2017 Special Issue of International Journal of Electronics, Communication & Soft Computing Science and Engineering, ISSN: 2277-9477
- [6] S. J. Sugumar and R. Jayaparvathy, “An early warning system for elephant intrusion along the forest border areas,” Current Science, vol. 104, pp. 1515–1526, 2013. View at Google Scholar

- [7] R. Radha, K. Kathiravan, V. Vineeth, J. Sanjay and S. Venkatesh, "Prevention of monkey trespassing in agricultural field using application agricultural specific flooding approach in wireless sensor network," 2015 IEEE Technological Innovation in ICT for Agriculture and Rural Development (TIAR), Chennai, 2015, pp. 106-111.
- [8] Isha Dua, Pushkar Shukla, Ankush Mittal" A vision based human - elephant collision detection system" IEEE International Conference on Image Processing. (25Febrary, 2016) pp: 225-229
- [9] Sheela.S, Shivaram. K., Chaitra. U, Kshama. P, Sneha. K, Supriya. K" Low Cost Alert System for Monitoring the Wildlife from Entering the Human Populated Areas Using IOT Devices" International Journal of Innovative Research in Science, Engineering and Technology. (10 May,2016) Vol. 5, Special Issue 10, May 2016.
- [10] R.Newlin Shebiah, B.Deeksha,S.Aparna "Early warning system from threat of wild animals using raspberry pi" (ICRTECITA-2017).
- [11] Abhinav andDeshpande, Design and implementation of an intelligent security system for farm protection from wild animals, International journal of science and research,10(2),2016, 300-350.
- [12] K. A. Pranesh and K Saranya, Solar tracking system using DC motor, International journal on application of information and communication engineering, 4(2), 2015, 122-222.
- [13]AmanGarg, Ketankumar, Mrs. SanjuSaini,Solar tracking an efficient method of improving solar plant efficiency, International journal of electrical engineering (IJEE),15(1), 2015, 2321-2055.
- [14]Srinivasa Reddy Gudibandi M.Tech Student, JNTUA, Anantapuramu, A.P, India, Mr. M. Amarnath ,"Design of Smart Surveillance System using PIR and Ultrasonic Sensor", International Journal & Magazine of Engineering, Technology, Management and Research,November 2015.
- [15]Sang Gi Hong, Young Bag Moon, Nae Soo Kim USN/IoT Convergence Research Division, Electronics and Telecommunications Research Institute Daejeon, Republic of Korea, Window Energy Detection for Unmanned Surveillance with PIR Sensor, 2012 IEEE 11th International Conference on Trust, Security and Privacy in Computing and Communications.
- [16]T.Gayathri and S.Ragul Corn farmland monitoring using wireless sensor network, International Research Journal of Engineering and Technology (IRJET), e-ISSN: 2395-0056, Volume: 02 Issue: 08 | Nov-2015.